

NO. 23-HP-M0005

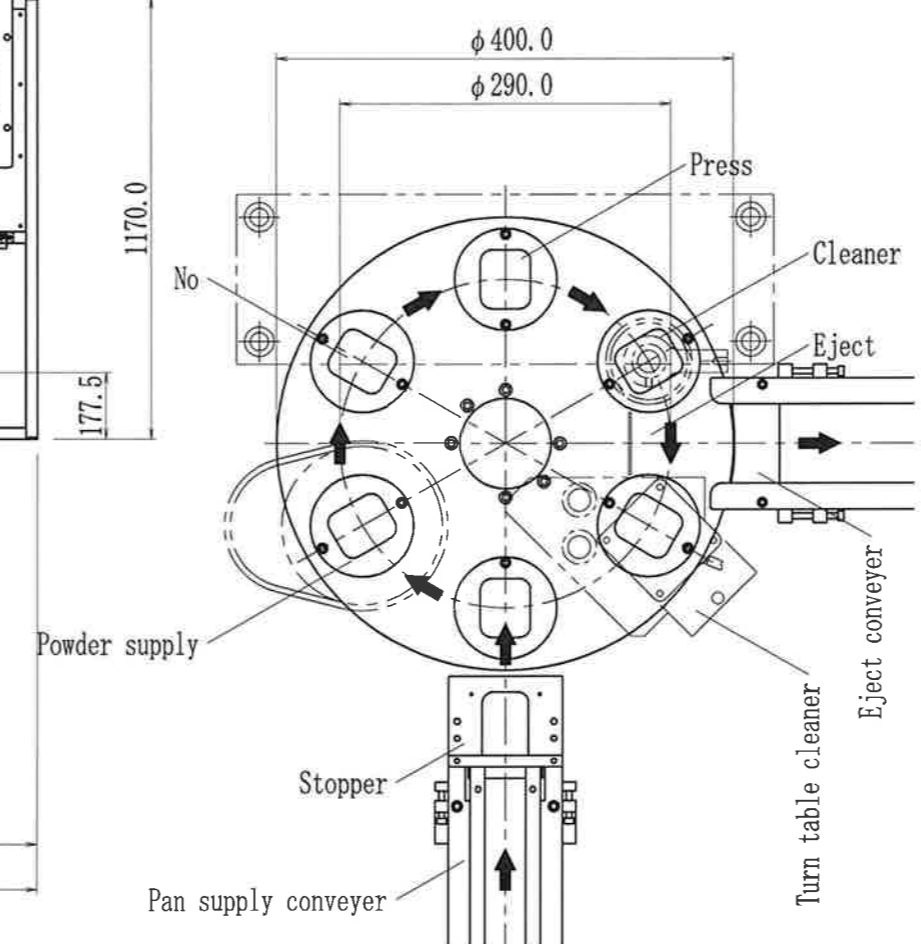

Specification  
 Power source Electric : AC200V(3Phases) 30A-1line  
 Air : More than 0.5Mpa-1 line  
 Object Cosmetic powder for foundation, eye shadow and so on.  
 Pan size Circle:diameter 60mm(max), Square:55mm(max)  
 Pressure 5KN - 35KN  
 Powder supply 5mm - 20mm (Depth)  
 Speed 30 cycle/min, In case of total press time less than 0.8 sec.  
 Possible to apply for 2 pans in 1 mold.  
 Material SUS304, AL, NAK-55, S50C, Trflon, Resin and so on.  
 Pan hopper Automatic pan supply with pan feeder and pan hopper to conveyer.  
 Printing with silicon pad  
 Pan supply Pick-and-place system by suction from conveyer to turn table.  
 Powder supply Automatic powder supply by vibration feeder and sub hopper into the powder hopper.  
 Powder hopper Rotation movement of the hopper and agitator to supply the powder in the pan.  
 Press Servo motor  
 Eject Net conveyer  
 Operator 1 operator

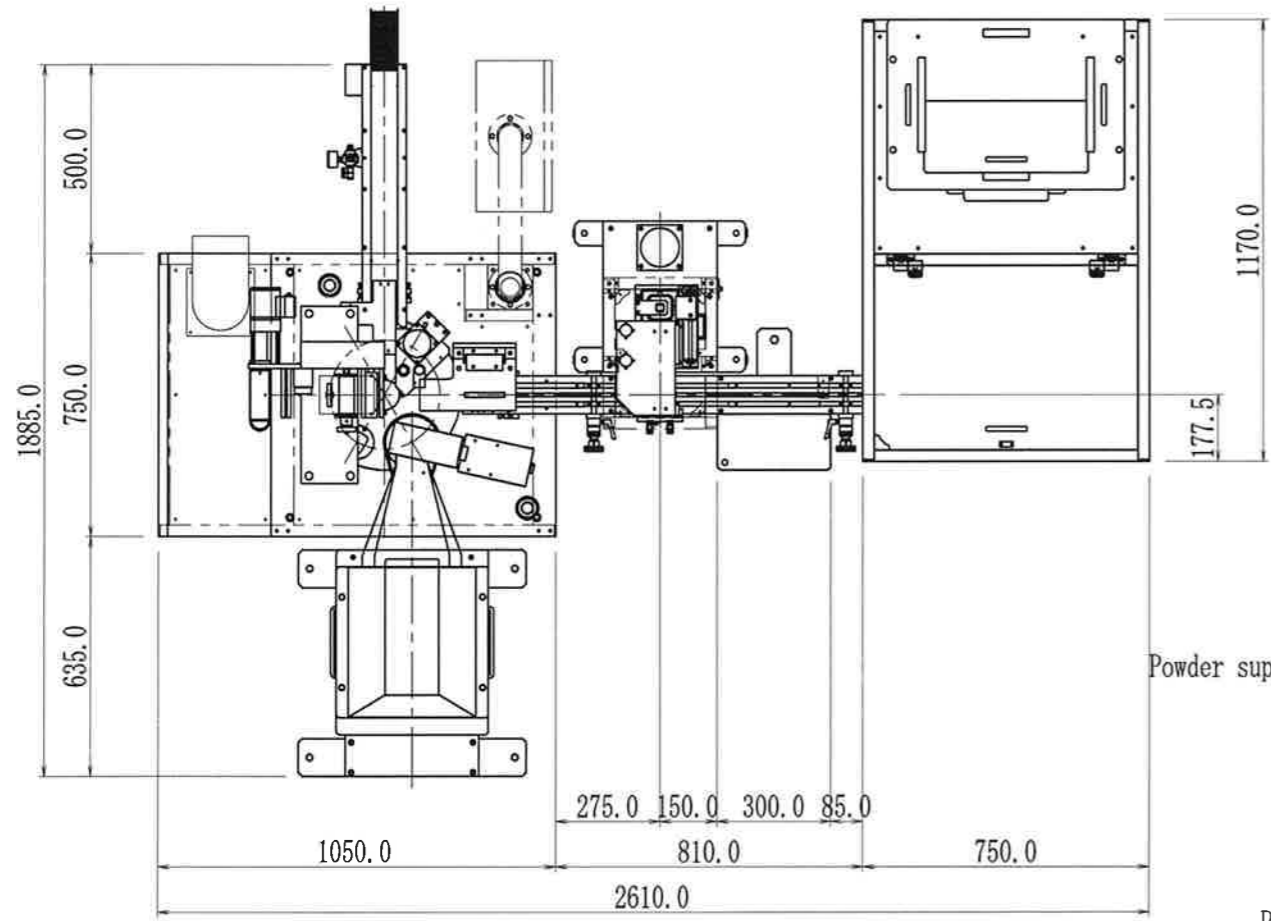
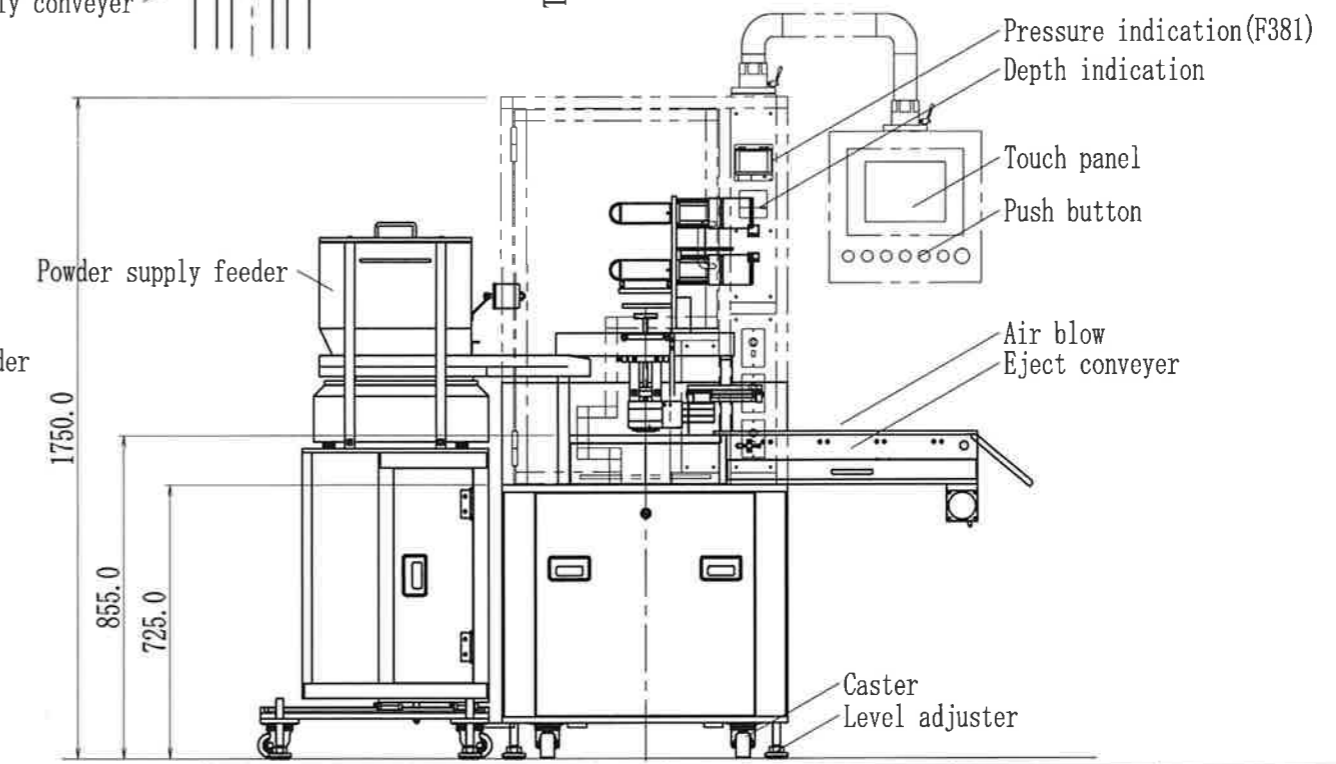
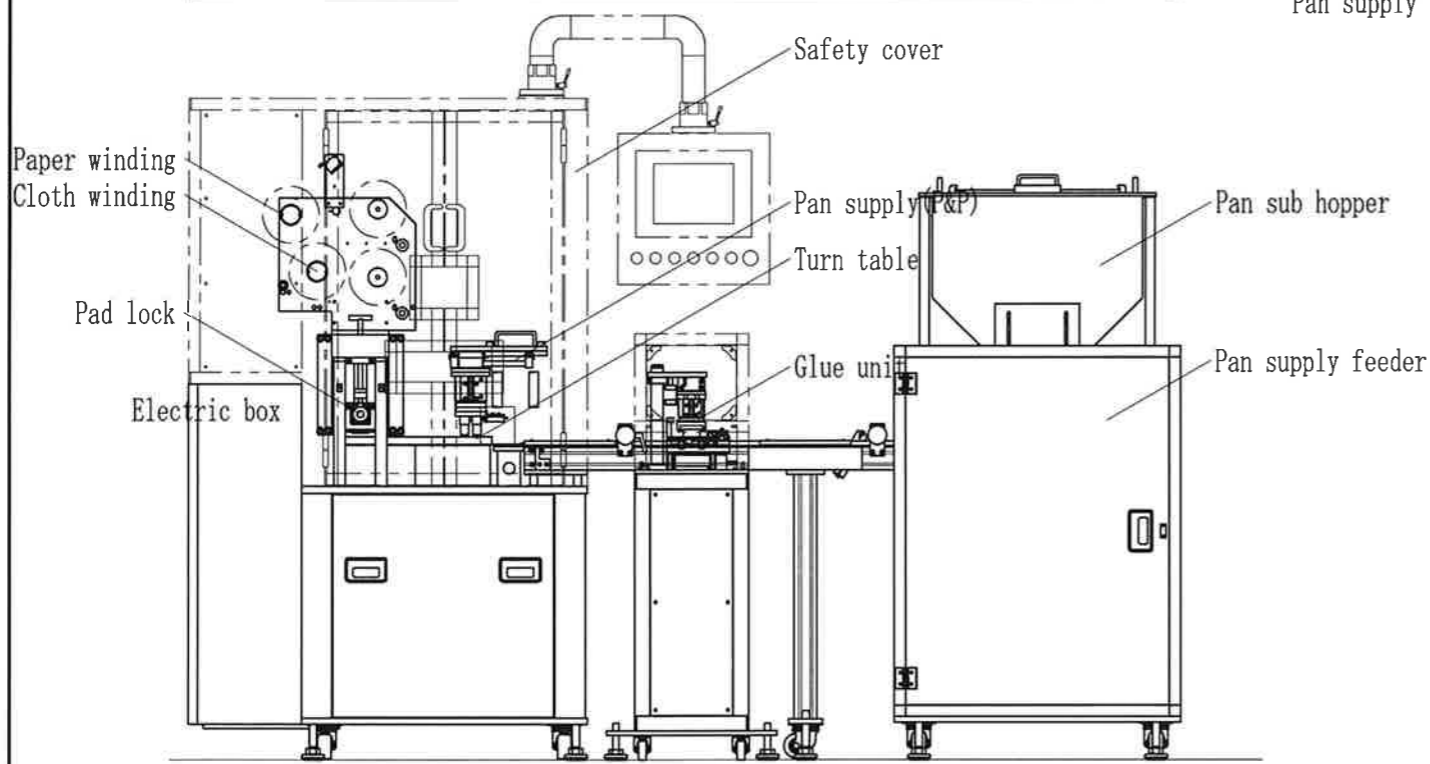

			PLAN	DR	11' 07/05	CHK	11' 07/05	APP
			M. Arashida		K. Arashida		K. Arashida	M. Arashida
			SCALE					
LTR	REVISION RECORD	DR	CHK	DATE	1:20			
			M/C NAME	6ST Servo shot		TITLE		
						Reference drawing for web site		